

OPTION (Handle, Wheel, Brake, Pump)



Hand Pallet Truck **HP** series

One of best selling in the world.

- ◆ A built in overload valve and totally sealed hydraulic pump.
- ◆ German seal kit offers long span life of pump for 3 years warranty.
- ◆ Heavy duty and reinforced forks for greatest strength and durability.
- ◆ Guide rollers offer easier entry and exit.
- ◆ Maintenance free oilless bushings at key points offer you less operating force and longer life span.
- ◆ Conforms to EN1757-2.

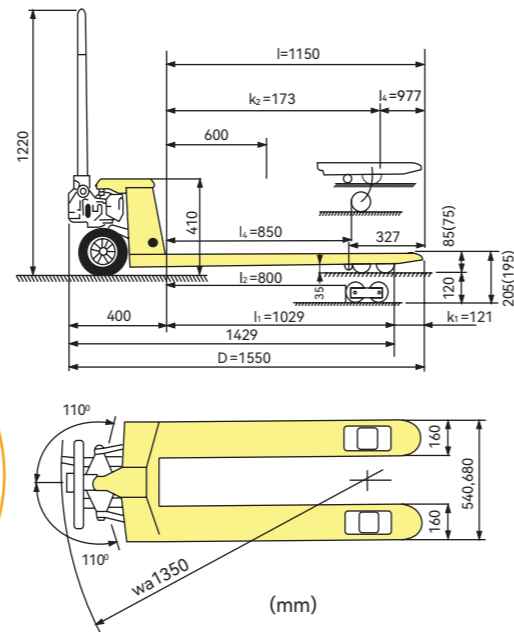

Special Size:
Fork Length: 800,1000
Fork Width: 450



Model	HP20S	HP20L	HP25S	HP25L	HP30S	HP30L
Capacity (kg)	2000	2000	2500	2500	3000	3000
Max. Fork Height (mm)	205 (or 195)	205 (or 195)	205 (or 195)	205 (or 195)	205 (or 195)	205 (or 195)
Min. Fork Height (mm)	85 (or 75)	85 (or 75)	85 (or 75)	85 (or 75)	85 (or 75)	85 (or 75)
Fork Length (mm)	1150	1220	1150	1220	1150	1220
Width Overall Forks (mm)	540	680	540	680	540	680
Individual Fork Width (mm)	160	160	160	160	160	160
Load Roller Dia. x W (mm)	Ø80×70 (or Ø70×70) Nylon, Polyurethane					
Steering Wheel Dia. x W (mm)	Ø200×50 (or Ø180×50) Nylon, Polyurethane, Rubber					
Net Weight (kg)	78	82	80	84	85	89
Quick Lift (6 pump strokes)	HPQ20S	HPQ20L	HPQ25S	HPQ25L	HPQ30S	HPQ30L
With Hand Brake	HPH20S	HPH20L	HPH25S	HPH25L	HPH30S	HPH30L
With Deadman Brake	HPD20S	HPD20L	HPD25S	HPD25L	HPD30S	HPD30L
With Foot Brake	HPJ20S	HPJ20L	HPJ25S	HPJ25L	HPJ30S	HPJ30L

Hand Pallet Truck **BST** series

- ◆ Ergonomic handle!
- ◆ New fork design ensures 25% more strength than standard fork.
- ◆ New adjustable push rod !
- ◆ Extremely easy to adjust push rod without turn the truck.



Model	BST2053	BST2068	BST2553	BST2568	BST3054	BST3068
Capacity (kg)	2000	2000	2500	2500	3000	3000
Max. Fork Height (mm)	205 (or 195)	205 (or 195)	205 (or 195)	205 (or 195)	205 (or 195)	205 (or 195)
Min. Fork Height (mm)	85 (or 75)	85 (or 75)	85 (or 75)	85 (or 75)	85 (or 75)	85 (or 75)
Fork Length (mm)	1150	1220	1150	1220	1150	1220
Individual Fork Width (mm)	150	150	150	150	160	160
Width Overall Forks (mm)	530	685	530	685	540	680
Net Weight (kg)	75	78	77	80	85	88

Hand Pallet Truck **AC/BF** series

- ◆ Rubber coated handle comfortable even under extreme temperature conditions.
- ◆ Fully sealed hydraulic unit housing.
- ◆ Single valve cartridge for easy maintenance.
- ◆ Powder coated chassis made of high grade steel.
- ◆ Conforms to EN1757-2.

NEW



Model	AC/BF25S	AC/BF25L	AC/BF30S	AC/BF30L
Capacity (kg)	2500	2500	3000	3000
Max. Fork Height (mm)	200 or 190	200 or 190	200 or 190	200 or 190
Min. Fork Height (mm)	85 or 75	85 or 75	85 or 75	85 or 75
Fork Length (mm)	1150	1220	1150	1220
Fork Overall Width (mm)	540	685	540	685
Fork Width (mm)	160	160	160	160
Front Wheel (mm)	Ø80×70 or Ø74×70, Nylon, Polyurethane			
Steer Wheel (mm)	Ø200 or Ø180×50 Nylon, Polyurethane, Rubber			
Net Weight (kg)	75	78	78	81

Hand Pallet Truck **DFE / DF** series

- ◆ Bushings at key points.
- ◆ Super strong steel structure frame.
- ◆ Tapered fork tips with entry guide roller.
- ◆ Fully adjustable push rods on forks.
- ◆ Conforms to EN1757-2.



Model	DFE15	DFE20	DF20	DF25	DF30
Capacity (kg)	1500	2000	2000	2500	3000
Max. Fork Height (mm)	175	200 or 195	200 or 195	200 or 195	200 or 195
Min. Fork Height (mm)	75	85 or 75	85 or 75	85 or 75	85 or 75
Fork Length (mm)	1200	1150	1150	1150	1150
Width Overall Forks (mm)	460/530/650	520/550/685	450/520/550/685	450/520/550/685	450/520/550/685
Individual Fork Width (mm)	130	160	160	160	160
Load Roller Dia. x W (mm)	Ø70 Single Nylon or Polyurethane		Tandem Ø80×70 or Ø74×70, Single Ø80×93 or Ø74×93 Nylon, Polyurethane		
Steering Wheel Dia. x W (mm)	Ø160×45 Nylon or Polyurethane				
Net Weight (kg)	50	60	62	64	80