

High Lift Scissor Truck **HL** series

- ◆ **Manual**
Capacity 1000kg (2200lbs).
Larger piston offer real 1000kg full capacity.
◆ Conforms to EN 1757-4.
- ◆ **Electric**
Capacity 1000kg (2200lbs).
High quality hydraulic motor made in Italy.
◆ Conforms to EN 1757-4 and EN 1175.
- ◆ All parts are made of stainless 316 including hydraulic pump, fork frame, handle, push rod, bearing, pin and bolt, etc.. (HS)



HL-5410M

HL-5410E

HL-6815E

Model	HL5410M	HL5415M	HL6810M	HL6815M	HL5410E	HL5415E	HL6810E	HL6815E
Type	<i>Manual</i>				<i>Electric</i>			
Capacity (kg)	1000	1500	1000	1500	1000	1500	1000	1500
Max. Fork Height (mm)	800	800	800	800	800	800	800	800
Min. Fork Height (mm)	80	80	80	80	80	80	80	80
Fork Overall Width (mm)	540	540	680	680	540	540	680	680
Fork Length (mm)	1165	1165	1165	1165	1165	1165	1165	1165
Battery (Ah/V)	-	-	-	-	54/12	54/12	54/12	54/12
Battery Charger (A/V)	-	-	-	-	8/12	8/12	8/12	8/12
Net Weight (without battery) (kg)	110	130	125	140	150	170	165	180

Rollers: Nylon, Polyurethane. **Wheels:** Nylon, Polyurethane, Rubber.
Materials and specification are subject to change without notice.

High Lift Scissor Truck **HS** series

- ◆ **Manual**
Capacity 1000kg (2200lbs).
Larger piston offer real 1000kg full capacity.
◆ Conforms to EN 1757-4.
- ◆ **Electric**
Capacity 1000kg (2200lbs).
High quality hydraulic motor made in Italy.
◆ Conforms to EN 1757-4 and EN 1175.
- ◆ All parts are made of stainless 316 including hydraulic pump, fork frame, handle, push rod, bearing, pin and bolt, etc.. (HS)



HS (Stainless)

Model	HS540M	HS680M	HS540E	HS680E
Type	<i>Manual</i>		<i>Electric</i>	
Capacity (kg)	1000	1000	1000	1000
Max. Fork Height (mm)	800	800	800	800
Min. Fork Height (mm)	80	80	80	80
Fork Overall Width (mm)	540	680	540	680
Fork Length (mm)	1165	1165	1165	1165
Battery (Ah/V)	-	-	54/12	54/12
Battery Charger (A/V)	-	-	8/12	8/12
Net Weight (without battery) (kg)	116	125	144	149

Rollers: Nylon, Polyurethane. **Wheels:** Nylon, Polyurethane, Rubber.
Materials and specification are subject to change without notice.

High Lift Scissor Truck **HB** series

The best selling in the world !

- ◆ **Single stage cylinder:** No decrease of capacity. No risk of leakage. No dangerous dropping of second stage cylinder.
- ◆ **Ergonomic design handle.**
- ◆ **Improved safety:** Automatic activation of self-adjusting stabilizers when lifting loads higher than 400mm for maximum stability and optimum braking.
- ◆ **Excellent manoeuvrability** due to compact design the compact structure with the battery and power unit positioned between body and lifting cylinder resulting in a low center of gravity .
- ◆ **Flexibility:** Can work manually when the battery has been charged.
- ◆ Conforms to EN1757-4 and EN1175.
- Manual**
- ◆ Quick-lift function doubles the lifting speed when lifting loads less than 250kg.
- Electric**
- ◆ Charger: 10A/12V separated, or 6A/12V Built-in.
- ◆ European Technology power unit.

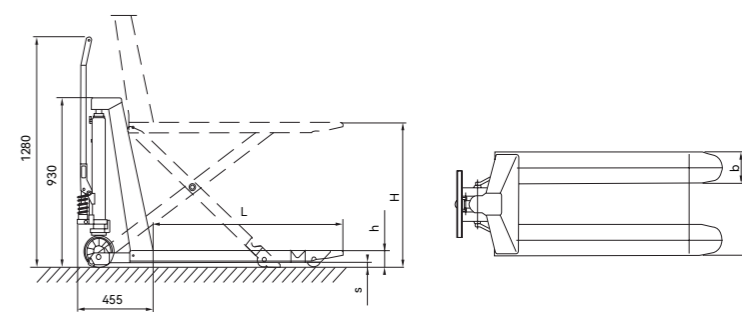

HB1056M



HB1056E



Built-in charger

Model	HB1056M	HB1068M	HB1056E	HB1068E	HB1056EN	HB1068EN
Type	<i>Manual</i>		<i>Electric</i>		<i>Electric (built in charger)</i>	
Capacity (kg)	1000	1000	1000	1000	1000	1000
Max. / Min. Fork Height H/h (mm)	800/85 ± 2	800/85 ± 2	800/85 ± 2	800/85 ± 2	800/85 ± 2	800/85 ± 2
Fork Size B×L (mm)	560×1190	680×1190	560×1190	680×1190	560×1190	680×1190
Front Load Roller (mm)	Ø75×75	Ø75×75	Ø75×75	Ø75×75	Ø75×75	Ø75×75
Steering Wheel (mm)	Ø180×50	Ø180×50	Ø180×50	Ø180×50	Ø180×50	Ø180×50
Lifting Time, without / with Rated Load (sec)	-	-	11/19	11/19	11/19	11/19
Battery (Ah/V)	-	-	70/12	70/12	70/12	70/12
Battery Charger	-	-	Separate 10A/12V		Built-in 6A/12V	
Net Weight (without Battery) (kg)	128	133	158	163	159	164