

Platform Stacker EP-A series

Manual

- ◆ Robust construction.
- ◆ Hard chromium plated frame.
- ◆ Effortless Movement.
- ◆ Polyurethane rollers with bearing.
- ◆ No-marking castor as standard.
- ◆ Conforms to EN1757-1.

Electric

- ◆ High quality hydraulic motor made in Korea.
- ◆ Service free battery.
- ◆ No-marking castor as standard.
- ◆ Conforms to EN1757-1.



Stainless steel as option.

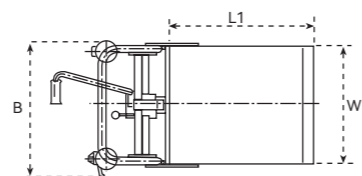
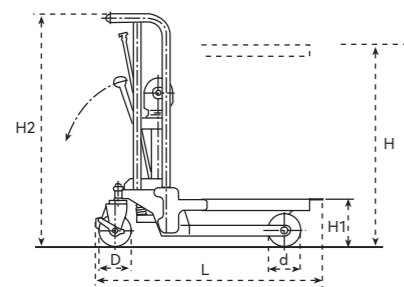

Model		EP2085A	EP2120A	EP4085A	EP4120A	EP4150A
Capacity	(kg)	200	200	400	400	400
Platform Height Max.	H (mm)	850	1200	850	1200	1500
Platform Height Min.	H1 (mm)	200	200	200	200	200
Platform Length	L1 (mm)	600	600	650	650	650
Platform Width	W (mm)	500	500	550	550	550
Total Length	L (mm)	990	990	1070	1070	1070
Total Width	B (mm)	560	560	590	590	590
Total Height	H2 (mm)	960	1310	970	1310	1610
Steering Rollers-Diameter	D (mm)	Ø125	Ø125	Ø150	Ø150	Ø150
Frame Rollers-Diameter	d (mm)	Ø75	Ø75	Ø75	Ø75	Ø75
Power Motor	(KW)	0.8	0.8	0.8	0.8	0.8
Battery	(Ah/V)	60/12	60/12	70/12	70/12	70/12
Pump Strokes to Max. Height		14	21	30	45	58
Net Weight	(kg)	88	93	107	113	118
Noise-free Castor		0	0	0	0	0

0 = Option

Mini Counter Balance Truck EZ series

Model		EZ2585	EZ2512	EZ2515
Capacity	(kg)	200-250	150-250	150-250
Max. Fork Height	(mm)	750	1100	1400
Min. Fork Height	(mm)	20 (60)	20 (60)	20 (60)
Fork Size (Low)	(mm)	550×70		
Fork Size (Standard)	(mm)	600×100		
Adjustable Fork Width	(mm)	1555-550(Low) 215-550(Standard)		
Front Wheel Size	(mm)	Ø125×50		
Rear Wheel Size	(mm)	Ø125×50		
Power Unit	(V/W)	DC 12V/800W		
Battery	(V/Ah)	DC12V/60Ah		
Overall Size (LxWxH)	(mm)	1500×720×1090/1440/1740		
Net Weight	(kg)	218	225	230
Option Platform		LP20		



Non-standard customized

Semi-Electric Stacker E200T / E400T

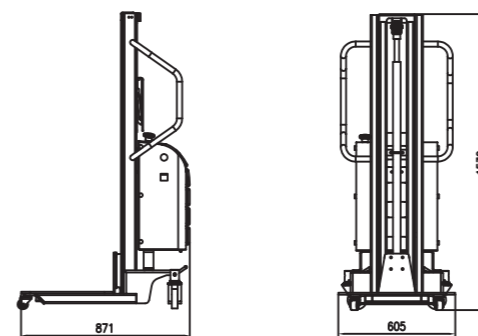

E400T

E200T

Model		E200T	E400T
Capacity	(kg)	200	400
Overall Length	(mm)	871	871
Overall Width	(mm)	605	605
Overall Height	(mm)	1532	1532
Max. Fork Height	(mm)	2250	2250
Min. Fork Height	(mm)	90	90

Mini Type Hand Stacker SHS150



Model		SHS150
Capacity	(kg)	150
Lifting Height	(mm)	870
Fork Length	(mm)	545
Fork Width	(mm)	140-510
Single Fork Width	(mm)	70×30
Min. Fork Height	(mm)	80
Rear Wheel Dia.	(mm)	200 Solid Rubber
Leg Length	(mm)	445
Leg Width	(mm)	490
Front Wheel	(mm)	50
Overall (LxWxH)	(mm)	820×650×1220
Net Weight	(kg)	43