

Semi-Electric Stacker EMS series

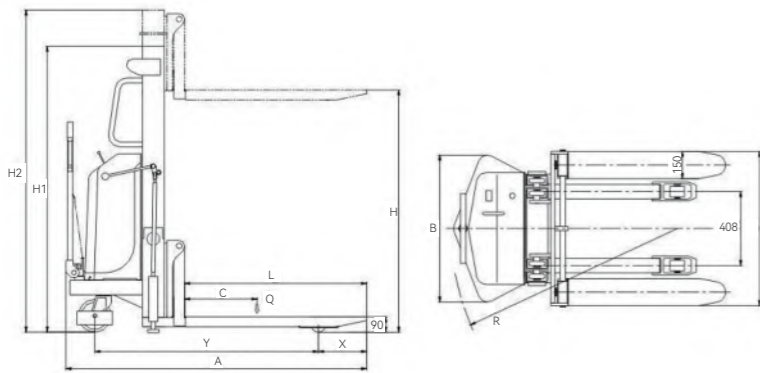

EMS



EMSS

Model	EMS1016	EMS1020	EMS1025	EMS1030	EMS1035	EMS1520	EMS1525	EMS1530	EMS1535	EMS2016	EMS2020	EMSS1016
Rated Capacity (kg)	1000	1000	1000	1000	1000	1500	1500	1500	1500	2000	2000	1000
Load Center (mm)	400	400	400	400	400	400	400	400	400	400	400	400
Max. Fork Height (mm)	1600	2000	2500	3000	3500	2000	2500	3000	3500	1600	2000	1600
Max. Machine Height (mm)	2060	2560	3060	3560	4060	2560	3060	3560	4060	2060	2560	2010
Fork Length (mm)	1000	1000	1000	1000	1000	1000	1000	1000	1000	1000	1000	1000
Fork Width (mm)	300-850	300-680	300-680	300-680	300-680	300-680	300-680	300-680	300-680	320-850	300-680	300-680
Min. Turning Radius (mm)	1350	1350	1350	1450	1450	1350	1350	1450	1450	1350	1350	1350
Wheel Base (mm)	1180	1185	1185	1185	1185	1185	1185	1185	1185	1180	1185	1025
Front Wheel Distance (mm)	322	316	316	316	316	316	316	316	316	322	316	300
Lifting Motor (V/kw)	12/1.6	12/1.5-1.6	12/1.5-1.6	12/1.5-1.6	12/1.5-1.6	12/1.5-1.6	12/1.5-1.6	12/1.5-1.6	12/1.5-1.6	12/1.6	12/1.5-1.6	12/1.5
Aneroid Battery (V/Ah)	12/120	12/120-150	12/120-150	12/120-150	12/120-150	12/120-150	12/120-150	12/120-150	12/120-150	12/120	12/120-150	12/120-150
Charger (V/A)	12/15	12/15	12/15	12/15	12/15	12/15	12/15	12/15	12/15	12/15	12/15	12/15
Overall Length (mm)	1670	1660	1660	1660	1660	1660	1660	1660	1660	1670	1660	1500
Overall Width (mm)	865	810	810	930	930	810	810	930	930	865	810	850
Overall Height (mm)	2060	1580	1830	2080	2330	1580	1880	2080	2380	2060	1580	2010
Net Weight (kg)	350	425	450	470	500	450	475	495	520	390	470	275

Fix forks available.

Mini Electric Forklift CPDM series

- ◆ DC24V, Curtis SEM control system.
- ◆ Compact design for using in narrow area.
- ◆ Three wheels for easy maneuverability.
- ◆ Max. capacity: 1000kg.

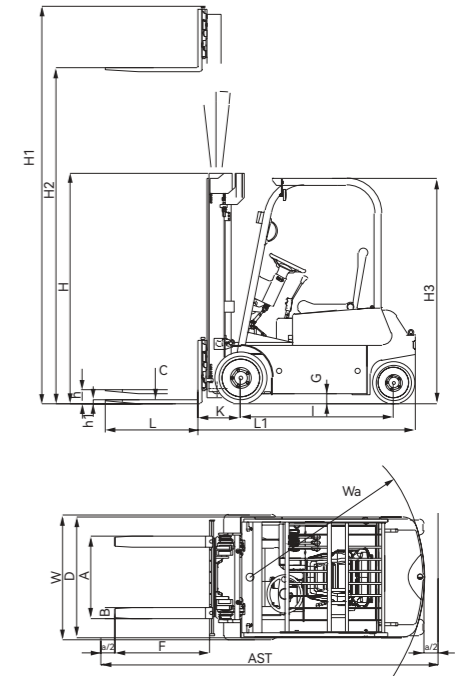

Model		CPDM05	CPDM75	CPDM100
Capacity	(kg)	500	750	1000
Load Center	C (mm)	400	400	400
Lifting Height	H2 (mm)	3200	3200	3200
Free Lifting Height	h (mm)	1600	1600	1600
Tilting Angle	Y1/Y2 (°)	2°/5°	2°/5°	2°/5°
Fork Length	L (mm)	800	800	800
Fork Width	B (mm)	100	100	100
Fork Width	A (mm)	220-680 (adjustable)	220-680 (adjustable)	220-680 (adjustable)
Side Shift	a/2 (mm)	left/right 100	left/right 100	left/right 100
Min. Turning Radius	Wa (mm)	1100	1260	1350
Lifting Speed	(m/min)	84/127	84/127	84/127
Lowering Speed	(m/min)	adjustable	adjustable	adjustable
Mast Height	H (mm)	1900	1900	1900
Max. Lifting Height	H1 (mm)	3600	3600	3600
Safe Guard Height	H3 (mm)	1900	1900	1900
Wheel Base	(mm)	860-940	860-940	860-940
Distance Front Between Wheels	(mm)	660	660	660
Min. Clearance to the Ground	G (mm)	85	90	90
Travelling Speed (with/without load)	(m/min)	6.5/7.8	6.5/7.3	6.5/7.0
Gradeability	(°)	8	8	8
Battery	(Ah/V)	210/24	280/24	385/24
AST	(mm)	2365	2365	2365
Driving Motor	(KW)	2.0	2.0	2.0
Pump Motor	(KW)	2.8	2.8	2.8
Wheel		Solid Rubber	Solid Rubber	Solid Rubber
Front Wheel		Ø267×127	Ø267×127	Ø267×127
Rear Wheel		Ø267×127	Ø267×127	Ø267×127
Overall Size	L1×W×H (mm)	1260×820×2100	1260×820×2100	1260×900×2100
Net Weight	(kg)	1250	1380	1550

1000mm Fork is available.