

Mobile Lift Table YTG series

- ◆ Economic range but reliable.
- ◆ Conforms to EN1570.



Model		YTG50	YTG100
Capacity	(kg)	500	1000
Min. Height	(mm)	290	360
Max. Height	(mm)	915	1360
Table Size (LxW)	(mm)	1600x810	2035x750
Wheel Size	(mm)	Ø125x40	Ø180x50/Ø80x40
Pump Times		≤ 55	≤ 200
Net Weight	(kg)	154	198

Lift Table TC series

- ◆ Heavy duty range.
- ◆ New design to meet norm EN1570: 1999.
- ◆ New hydraulic system safety.
- ◆ Welded front wheel bracket.
- ◆ Assembling handel.



Model		TC22Y	TC45P
Capacity	(kg)	220	450
Max. Lift Height	(mm)	724	876
Min. Height	(mm)	235	279
Platform Size (LxW)	(mm)	705x450	813x508
Package Size	(mm)	810x490x245	980x560x290
Gross Weight	(kg)	44.5	78.5
Net Weight	(kg)	40.5	74

Scissor Table SC series

Features & Benefits

- ◆ Simple, compact design.
- ◆ Fully complying product.
- ◆ Manual operation.
- ◆ All tables fitted with service props.
- ◆ Simple to add rollers etc.
- ◆ Fully serviceable components.
- ◆ Fast moving product line.
- ◆ Cooperation with Advanced Handling, UK.

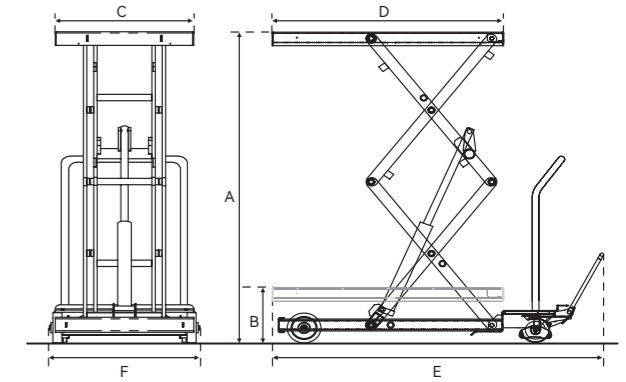

Option-roller shaft platform



SC-300-D-M



SC-500-S-M



SC-500-T-E

Model		SC-125-D-M	SC-150-S-M	SC-300-S-M	SC-300-D-M	SC-450-D-M	SC-500-S-M	SC-500-T-E
Capacity	(kg)	125	150	300	300	450	500	500
Max. Height	A (mm)	1420	780	840	1350	1550	900	2900
Min. Height	B (mm)	430	255	335	295	295	340	650
Platform Width	C (mm)	500	450	500	590	610	610	840
Platform Length	D (mm)	840	760	840	840	1030	1030	1350
Overall Size	ExF (mm)	1090x500	990x450	1050x500	1190x640	1350x665	1320x610	1660x950
Scissors		2	1	1	2	2	1	3
Operation		Manual	Manual	Manual	Manual	Manual	Manual	Electric
Net Weight	(kg)	85	41	83	102	143	106	600