

Lift Table QT series

- ◆ Heavy duty range.
- ◆ New design to meet norm EN1570: 1999.
- ◆ New hydraulic system increases safety and protects your goods, tepless rate of lowering system remains irrespective of the weight of the load.

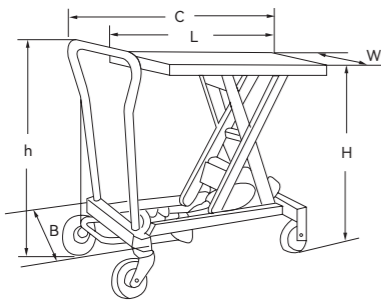

Model		QT15	QT25	QT50	QT75	QT100	QT30D	QT50D	QT80D	QT50L
Capacity	(kg)	150	250	500	750	1000	300	500	800	500
Table Size	L×W (mm)	700x450	830x500	1010x520	1010x520	1010x520	1010x520	1010x520	1010x520	1525x620
Table Height	H(Min./Max.) (mm)	265/755	330/910	435/1000	442/1000	445/950	435/1585	440/1585	470/1410	400/1100
Handle Height	h (mm)	1015	1085	1100	1100	1100	1100	1100	1100	1100
Wheel Dia.	(mm)	Ø100	Ø125	Ø150	Ø150	Ø150	Ø150	Ø150	Ø150	Ø150
Overall Size	B×C (mm)	450×930	500×1065	520×1275	520×1275	520×1275	520×1275	520×1275	520×1275	620×1780
Foot Pedal to Max. Height		22	30	65	75	80	65	75	80	100
Net Weight	(kg)	41	78	118	120	137	150	168	165	175

Lift Table HEX series

- ◆ Heavy duty range.
- ◆ New design to meet norm EN1570: 1999.
- ◆ New hydraulic system increases safety and protects your goods, tepless rate of lowering system remains irrespective of the weight of the load.

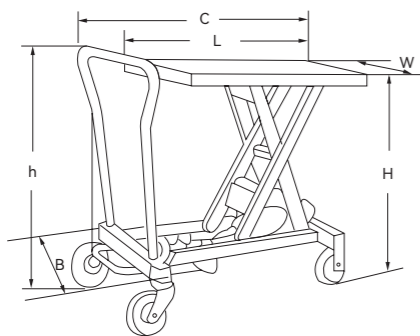

Model		HEX30	HEX50
Capacity	(kg)	300	500
Table Size	L×W (mm)	775×500	920×615
Table Height	H(Min./Max.) (mm)	280/810	300/940
Handle Height	h (mm)	900	950
Wheel Dia.	(mm)	Ø125	Ø125
Overall Size	B×C (mm)	960×500	1080×600
Foot Pedal to Max. Height		16	25
Net Weight	(kg)	65	118

CZD-Trolleys

- ◆ No trapping points between moving parts, minimizing the risk of trapped fingers.
- ◆ Service supports are fitted.
- ◆ Rear wheels are fitted with toe guards and brakes which stop the wheel from rotating and the swivel head from turning. All wheels have non-marking rubber rims and stainless steel roller bearings.
- ◆ Front wheels - The front wheels are fitted on long axles for improved stability and a tight turning circle. Anti trap toe guards are supplied as standard to help prevent accidental roll-over.
- ◆ Conforms to EN1570.

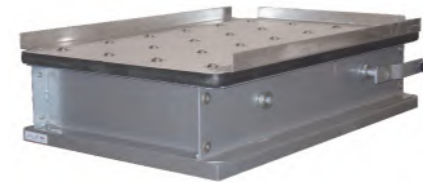

Accessories

Ball Transfer Table

Easier for loading and unloading operations by means of a ball transfer unit. As the steel balls are raised, the goods on the table are very easy to move into or move away. As the steel balls are lowered, the goods stay on table firmly.



- ◆ Different table size can be supplied.

Roller Track

Goods transported are secured by adjustable stoppers at both ends of the track.



Model	Capacity (kg)	Max. Height (mm)	Min. Height (mm)	Length (mm)	Width (mm)	Platform Size (mm)	Net Weight (kg)
CZD 203	200	1620	450	1150	650	900×600	85