

## Big Capacity Lift Table (Separated Pump) **CPTD** series



CPTD500/800



CPTD1000/1500

Model	Capacity (kg)	Table Size (mm)	Table Height (Min./Max.)(mm)	Wheel Dia. (mm)	Package Size (mm)	Net Weight (kg)
CPTD500	500	905×500	360/1500	125 (5")	1020×520×360	110
CPTD800	800	1200×610	450/1500	125 (5")	1380×610×460	150
CPTD1000	1000	1200×610	500/1700	150 (6")	1370×610×500	225

## Aluminum/ stainless Lift Table **BSA / YSS** series

- ◆ Robust structure yet light Weight.
- ◆ Made of stainless #304 (BSA is made of Aluminum).
- ◆ Two brakes increase safety.
- ◆ Stainless structure ideal for pharmaceutical, food, beverage etc.
- ◆ Conforms to EN1750.



BSA10



YSS25



YSS35D

Model	BSA10	YSS15	YSS25	YSS35D	YSS50
Capacity (kg)	100	150	200	350	500
Min. Height (mm)	265	265	330	355	380
Max. Height (mm)	755	755	910	1300	1000
Wheel Size (mm)	Ø100	Ø100	Ø125	Ø125	Ø125
Table Size (mm)	700×450	700×450	830×500	910×500	1000×520
Handel Height (mm)	1010	1000	1010	1100	1100
Overall Size (mm)	450×910	450×950	500×1010	1010×500	1120×530
Package Size (mm)	850×490×300	910×500×325	1010×500×1000	940×550×400	1050×580×430
Material	Aluminium	Stainless	Stainless	Stainless	Stainless
Foot Pedal to Max. Height	40	20	28	53	30
Net Weight (kg)	23	40	78	105	81

## Stainless Lift Table **BSS** series

- ◆ All made of stainless steel.
- ◆ Conforms to EN1570 and ANSI / ASME safety standard.
- ◆ Safety clearance between scissors to prevent from trapping.
- ◆ Swivel wheel with protection frame and brake to prevent foot from injury.



Built-in relief valve to fulfill overload protection.  
For use in food industry, medicine industry.



Model	BSS10	BSS20	BSS30	BSS50	BSS75
Capacity (kg)	100	200	300	500	750
Min. Height (mm)	265	330	330	435	442
Max. Height (mm)	755	910	910	1000	1000
Platform Size (mm)	700×450	830×500	830×500	1010×520	1010×520
Wheel Size (mm)	100	125	125	150	125
Overall Size (mm)	950×450×1000	1010×500×1000	1010×500×1000	1158×520×1000	1260×520×1000
Net Weight (kg)	40	78	80	118	137

## Electric Lift Table **ES** series

Lifts heavy loads with ease.

- ◆ Robust structure yet light weight.
- ◆ Power unit made in Korean, DC 800W.
- ◆ High quality battery 75Ah/12V.
- ◆ Automatic battery charger.
- ◆ Wheel and roller diameter 150mm.
- ◆ Handle height 1185mm.

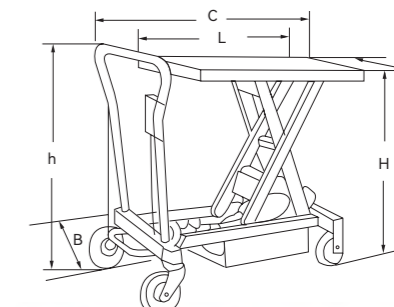

ES30D



ES50



ES50D

Model	Capacity (kg)	Table Size L×W (mm)	Table Height H (Min./Max.)(mm)	Lifting Cycle Fully Charged	Wheel Dia. (mm)	Lifting/Lowering Time (s)	Overall Size (mm)	Net Weight (kg)
ES30	300	1010×520	450/950	65	Ø100	15/15	520×1010	140
ES50	500	1010×520	450/950	55	Ø150	15/15	520×1010	148
ES75	750	1010×520	450/950	45	Ø150	15/15	520×1010	154
ES100	1000	1010×520	480/950	40	Ø150	15/15	520×1010	169
ES30D	300	1010×520	495/1600	45	Ø150	15/15	520×1010	183
ES50D	500	1010×520	495/1618	40	Ø150	15/15	520×1010	198
ES80D	800	1010×520	510/1460	40	Ø150	15/15	520×1010	210
ES91D	910	1010×520	510/1460	40	Ø150	15/15	520×1010	220