

Pallet Sping Positioner and Level Loader **SP-2000**

- ◆ Automatically maintain a load at the ideal height for manual loading and unloading.
- ◆ Automatically maintain the top of the load at the working height.
- ◆ Includes a steel scissor lift mechanism and at least one large compression spring.
- ◆ The springs are chosen to match the weight and height of a fully loaded pallet.
- ◆ With a shock absorber to eliminate tendency for the load to bounce on the springs.



Carousel pallet turn with brake



Option-Solid Disc with Cover



Stainless



Galvanized



Option-Skirt cover

| Model | SP-2000 | |
|-----------------------------|---------|----------------------|
| Capacity | (kg) | 200-2000 |
| Compressed Height | (mm) | 240 |
| Extended Height | (mm) | 710 |
| Rotation Ring, Outside Dia. | (mm) | Ø1110 |
| Rotating Ring Inside Dia. | (mm) | Ø1035 |
| Base Frame Length | (mm) | 1150 |
| Base Frame Width | (mm) | 930 |
| With 3 springs | | Large, Middle, Small |
| Net Weight | (kg) | 128 |

Electric Rotating Lift Table **ALT-EH / ALT-EP** series

- ◆ 360 degree rotating closed platform.
- ◆ Easy to be moved by the forklift.
- ◆ Internal power pack equipped with relief valve against overloading and compensated flow valve for controlled lowering speed.
- ◆ Heavy duty cylinders with drainage system and check valve to stop the lift table lowering in case of hose burst.
- ◆ With hand controller, foot pedal controller as optional.
- ◆ Single phase power supply as optional.
- ◆ External power unit as optional.



ALT-EH

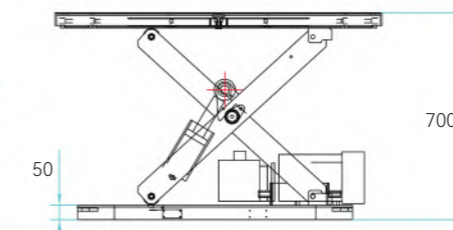
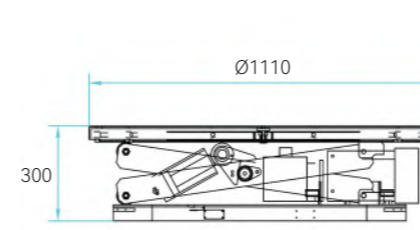
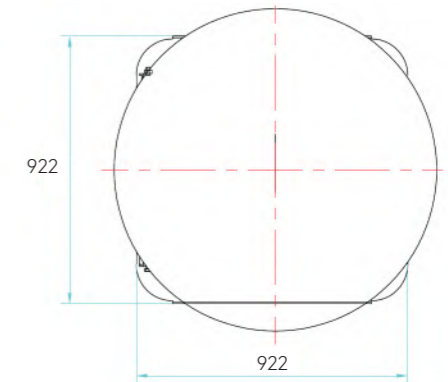

ALT-EP

| Model | ALT1000EH | ALT2000EH | ALT1000EP | ALT2000EP | |
|----------------------|-----------|----------------------|---------------------|----------------------|---------------------|
| Capacity | (kg) | 1000 | 2000 | 1000 | 2000 |
| Operation Type | (mm) | Electric (Handle) | Electric (Handle) | Electric (Pedal) | Electric (Pedal) |
| Diameter of Platform | (mm) | 1110 | 1110 | 1110 | 1110 |
| Min. Platform Height | (mm) | 300 | 300 | 300 | 300 |
| Max. Platform Height | (mm) | 700 | 700 | 700 | 700 |
| Basement Length | (mm) | 934 | 934 | 934 | 934 |
| Basement Width | (mm) | 922 | 922 | 922 | 922 |
| Lift Time | (s) | 15-20 | 20-25 | 15-20 | 20-25 |
| Power Pack | | 380V/50HZ, AC 1.1 KW | 380V/50HZ, AC 2.2KW | 380V/50HZ, AC 1.1 KW | 380V/50HZ, AC 2.2KW |
| Net Weight | (kg) | 163 | 175 | 164 | 176 |