

Drum Positioner *DH300*

- ◆ Steel drum 221/2" (572mm) diameter, 36" (915.5mm) high.
- ◆ Fork Opening: 241/2" (623mm) apart.
- ◆ Fork Pockets: 51/2" x 1/2" x 2" (140mm x 55mm x 560mm).



Model		DH300
Capacity	(kg)	300
Drum Size	(gallon)	55 (210 liters)
Overall Size	(mm)	1405×720×120
Net Weight	(kg)	42

Drum Positioner *DR400*

- ◆ For manipulating 210 litre steel or L and XL ring.
- ◆ Plastic drums from horizontal to vertical and vice-versa.
- ◆ Hinged tines lock automatically when lowered to ground in horizontal position.
- ◆ Ideal for loading/unloading drums stored horizontally on drum racking and stands.
- ◆ Suitable for loading drums onto vehicles.
- ◆ Completely mechanical operation.
- ◆ Can be operated without the driver leaving the seat of the truck.
- ◆ Easy-to-learn operating technique, written instructions provided.

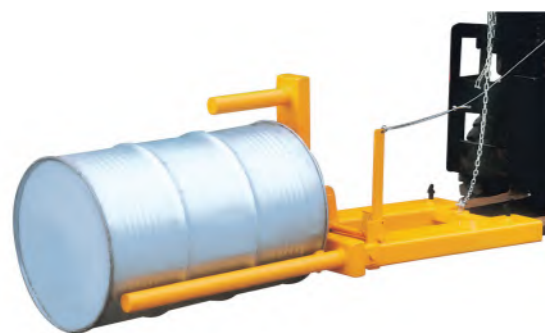

Model		DR400
Capacity	(kg)	400
Max. Fork	W×D (mm)	140×50
Fork Spread	(mm)	575
Overall Size	(mm)	1900×690×655
Net Weight	(kg)	75

Counterbalance Electric Drum Stacker *CES420* series

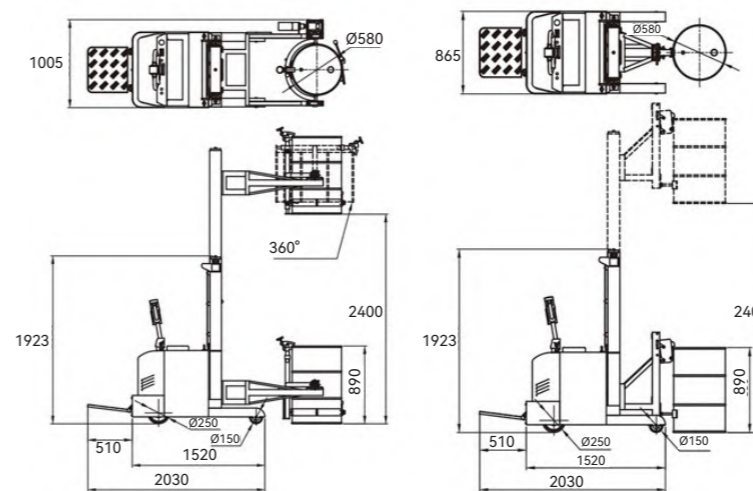

CES420



CES420A



CES420B

Model		CES420	CES420A	CES420B
Capacity	(kg)		420	
Lifting Height	(mm)		2400	
Turning Radius	(mm)		2150	
Gradeability (Load/Unload)	(%)		3/5	
Driving Motor	(V/Kw)		1.2	
Lifting Motor	(V/Kw)		2.2	
Driving Wheel	(mm)		PU, Ø250×80	
Battery	(V/Ah)		24/240	
Battery Charger	(A/V)		24/20	
Braking Method			Electromagnetic	
Dimension	(mm)	2840×1180×1923	2980×1005×1923	2270×865×923
Rotating Angle	(°)	175	360	0
Net Weight	(kg)	1100	1050	1100