

Full Electric Drum Stacker YL650 series

- ◆ Stable walking, lightweight, flexible, and can be operated by a single person;
- ◆ A multifunctional control handle that integrates human and machine,
- ◆ Stepless speed controller for walking
- ◆ High power directional switch
- ◆ Integrated hydraulic pump station
- ◆ High power walking drive wheel;
- ◆ YL650A manual gripping and electric flipping.
- ◆ YL650A-1 manual gripping, electric flipping, with electronic weighing.
- ◆ YL650B electric lift, buckle type eagle beak;

Option:

YL650A can be optionally equipped with remote control for lifting and flipping.

YL650B can be equipped with a single (double) eagle beak.

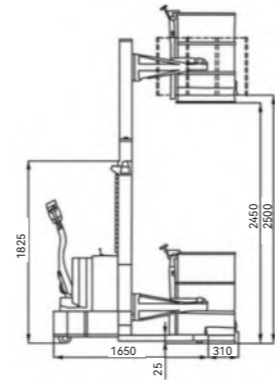
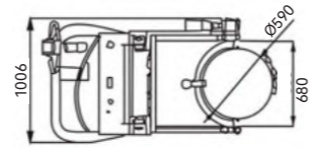

YL650A



YL650A-1

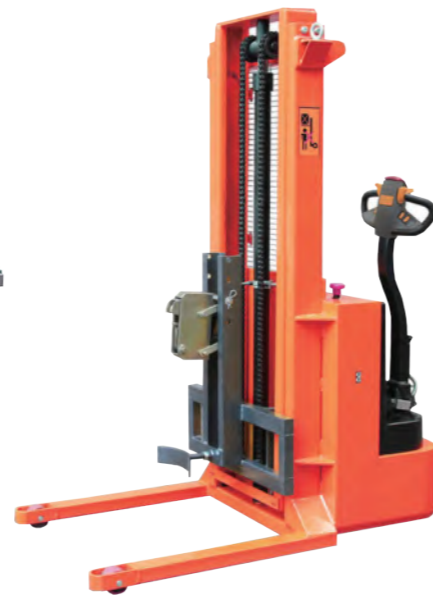

YL650B

| Model | YL650A | YL650A-1 | YL650B |
|---------------------------|-------------|-------------|-------------|
| Capacity (kg) | 650 | 650 | 650 |
| Lifting Height (mm) | 2400 | 2400 | 2400 |
| Turning Radius (mm) | 1650 | 1650 | 1650 |
| Gradeability(Load/Unload) | 3% / 5% | 3% / 5% | 3% / 5% |
| Driving Wheel (mm) | PU, Ø250×80 | PU, Ø250×80 | PU, Ø250×80 |
| Overall Length (mm) | 1960 | 1960 | 1450 |
| Overall Width (mm) | 1006 | 1006 | 865 |
| Overall Height (mm) | 1860 | 1860 | 1850 |
| Driving Motor (Kw) | 1.2 | 1.2 | 1.2 |
| Lifting Motor (Kw) | 2.2 | 2.2 | 2.2 |
| Battery (V/Ah) | 12/240 | 12/240 | 12/240 |
| Battery Charger (V/A) | 24/20 | 24/20 | 24/20 |
| Flip Angle (°) | 175 | 360 | - |
| Net Weight (kg) | 518 | 525 | 470 |

Mobile-Karrier HD series

A truly quality-built drum handler.

- ◆ Remarkable versatility ! Mobile-karrier raises, transports, rotates, tilts and drains fully loaded drums.
- ◆ It carries the full weight of the drum.
- ◆ Dual, fingertip operated locks secure the raised drum. It can lock a drum in vertical positioning to avoid spills or horizontal position for draining through a faucet. When unlocked, the drum may be tuened end-over-end to agitate contents or tipped and held manually at any angle.
- ◆ And it is very simple to move and steer on its 8" nylon or polyurethane roller bearing wheels and 4" swivel caster. A truly quality-built drum handler.
- ◆ It is shipped partly disassembled to save freight costs.



HD80A



HD80B

HD80B



HD80B-S

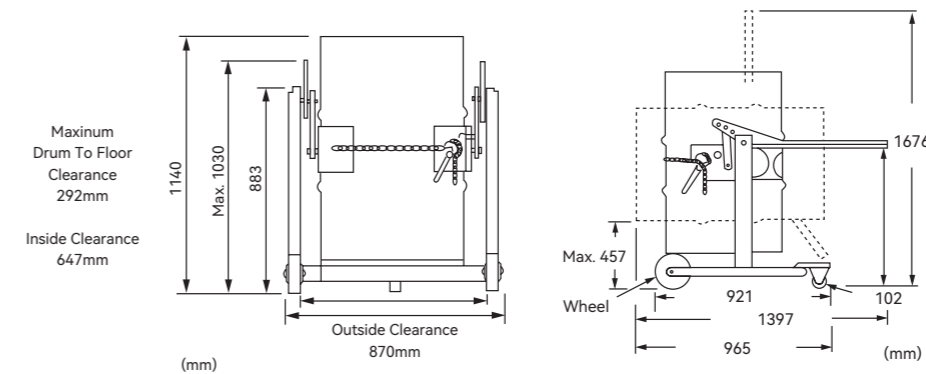

| Model | HD80A | HD80B | HD80C |
|--------------------|--|---|-------------------------------|
| Capacity (kg) | 364, Steel Drum | 365 | 365 |
| Drum Size | 572mm (22 ¹ / ₂ " Diameter, 210 Liters (55 gallon), 36" High (915.5mm) | 30-55gallon (Ø450×700~572×900) Steel drum | 30-50gallon/210L plastic drum |
| Net Weight (kg) | 50 | 46 | 43 |
| Overall Width (mm) | 870 | 870 | 800 |

Note:Stainless steel type is available.

Hydraulic Drum Truck HJ365

- ◆ One person operate easily.
- ◆ Only for carrying and moving, not for tilting.
- ◆ Lifting after grabbing firmly when operating.



| Model | HJ365 |
|-------------------------|------------------|
| Capacity (kg/lbs) | 365/800 |
| Acceptable Drum Style | 55 gallon, Steel |
| Max. Height of Arm (mm) | 390 |
| Min. Height of Arm (mm) | 270 |
| Radius of Arm (mm) | 290 |
| Overall Size L×W (mm) | 1022×722 |
| Net Weight (kg) | 53 |