

Hydraulic Drum Truck WA series

- ◆ Ergonomic lifts, transports, and places poly, steel, or fiber drums on or off pallets.
- ◆ A spring-loaded clamp securely holds any rimmed drum.
- ◆ High lifting height for ledge and car.
- ◆ Compact design and less effort operation.
- ◆ Disassembling easy and for small carton store.

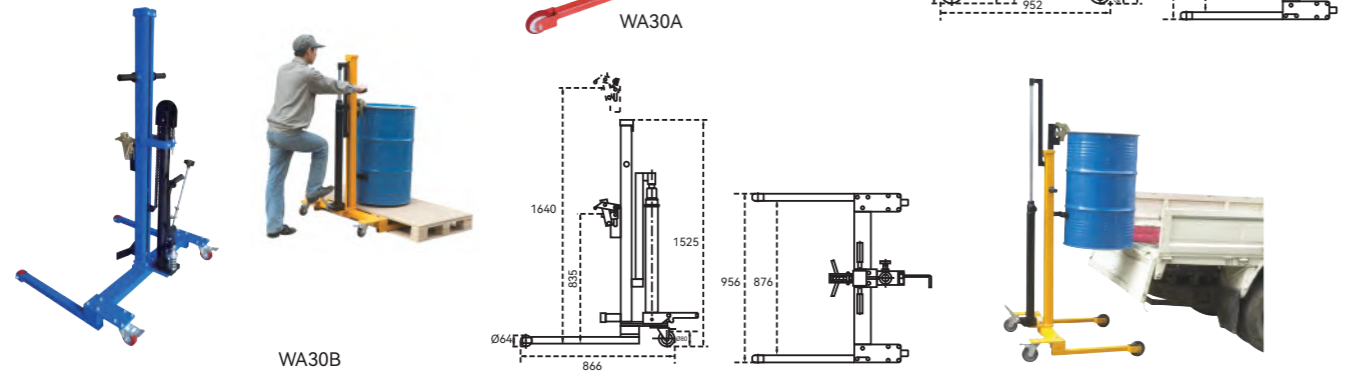

Model	WA30A	WA30B (Low Profile)
Lifting Capacity	(kg) 300	300
Drum Size	572mm (22½" Diameter), 210Liters (55 gallon)	
Front Wheel	Dia. xW (mm) Ø125×32	Ø64×37
Rear Castor	Dia. xW (mm) Ø125×32	Ø80×32
Dimensions	H1 (mm) 870	835
	H2 (mm) 1675	1640
Overall Dimensions	L×W×H (mm) 952×956×1560	866×956×1525
Net Weight	(kg) 72	68

Drum Lifting And Tilting Unit WB / WE series

- ◆ For lifting, turning, mixing, emptying and transporting drums.
- ◆ Hydraulic cylinder with pipe breakage protection. Hydraulic lifting with pedal. Drums are turned with hand crank. 2 castors, 1 swivel castor with wheel stop, solid rubber wheels.
- ◆ For 200 litre steel drums with rolling hoops.
- ◆ For plastic and steel drums diameter: 400mm.

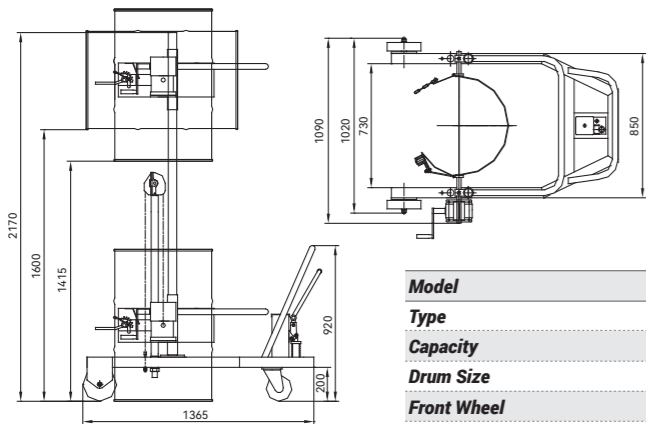

Model	WB30	WE30
Type	Manual	Electric
Capacity	(kg) 300	300
Drum Size	(mm) Ø572×900	Ø572×900
Front Wheel	(mm) Ø200	Ø200
Rear Wheel	(mm) Ø150	Ø150
Strokes to Max. Lifting Height Approx	82	-
Lifting Speed Approx	(mm/s) -	40
Power Unit	(KW) -	150
Battery	(V/Ah) -	12/60

Electric Drum Dumpers YL300

- ◆ With high quality hydraulic pump station and VARTA maintenance-free battery.
- ◆ Electric lift and electric rotation.
- ◆ Provide controlled dispensing of your drum.
- ◆ Lift, move, stack, tilt & drain your 55-gallon steel drum & 210L plastic drum.

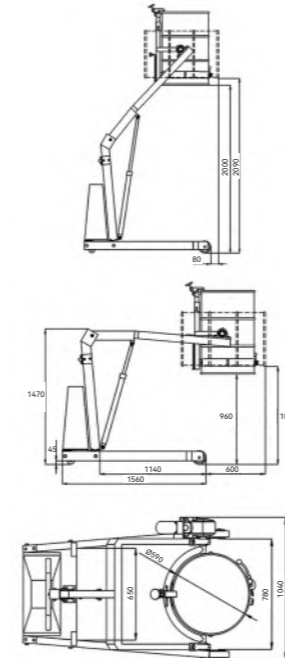

Model	YL300
Load Capacity	(kg) 300
Wheel Size	(mm) Ø150×50 (Front)/Ø100×50 (Rear)
Inside/Outside Width of Support Leg	(mm) 800 (inside)/930 (outside)
Turning Radius	(mm) 1750
Pump Power	(Kw/h) 0.8
Battery	(V/Ah) 12/100
Lifting Height	(mm) 2000 (upright drum)/2090 (horizontal drum)
Lifting Speed	(mm/s) 120
Acceptable Drum Size	(mm) Ø570-600
Overall Size	(mm) 1560×1040×1470
Net Weight	(kg) 220

Electric Drum Lifter Rotator YL400

- ◆ 45° degree tilt angle.
- ◆ Rotary switch control to power chute.
- ◆ Gravity down system with adjustable flow control to safely lower chute.
- ◆ Heavy-gauge carbon steel construction with enamel finish.
- ◆ Adopt integrated hydraulic pump stations and high quality hydraulic oil cylinder.
- ◆ Equipped VARTA maintenance-free battery.
- ◆ Optional AC power.
- ◆ Suitable for dumping all kinds of drums.
- ◆ Portable units have two rigid and two swivel casters with floor lock screws.
- ◆ Adjustable hold-downs keep container from shifting.

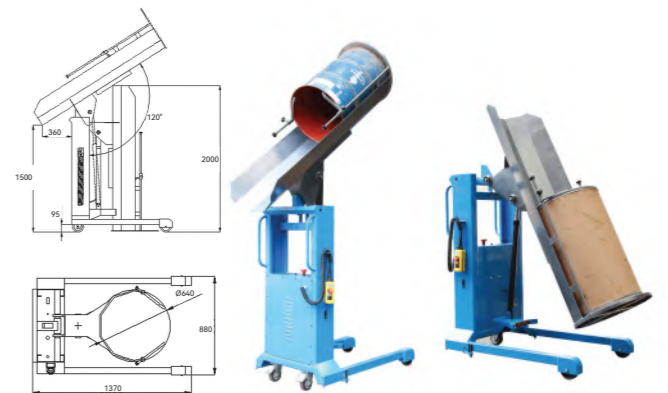

Model	YL400
Rated Load Capacity	(kg) 400
Dumping Height	(mm) 1500
Turning Radius	(mm) 1600
Wheel Dimension	(mm) Ø200×50/Ø150×50
Wheel Material	polyurethane
Pump Station Power	(kw/h) 1.5
Battery	(V/Ah) 12/120
Net Weight	(kg) 302
Rotating Angle	(°) 120