

Semi-Electric Drum Dumpers YL520 series

- ◆ Select high-quality hydraulic pump station with strong power.
- ◆ Using maintenance free batteries for long-lasting power.
- ◆ C-shaped homes made with special rolling technology, sturdy and safe.
- ◆ Integrated with clamp and knife buckle, suitable for steel oil drums and plastic oil drums.

YL520/YL520-1: Electric lifting, electric flipping.
YL520A/YL520A-1: Electric lifting, manual flipping.
YL520-1/YL520A-1: With electronic weighing device (optional).



Model	YL520	YL520-1	YL520A	YL520A-1
Capacity (kg)	520	520	520	520
Lifting Height (mm)	1500	1500	1500	1500
Lifting Speed (mm/s)	120	120	120	120
Wheel (mm)	Ø80×55 / Ø150×50	Ø80×55 / Ø150×50	Ø80×55 / Ø150×50	Ø80×55 / Ø150×50
Turning Radius (mm)	1620	1620	1620	1620
Pump Power (Kw/h)	1.6	1.6	1.6	1.6
Battery (Ah/V)	120/12	120/12	120/12	120/12
Net Weight (kg)	280	308	269	274

Lifting Clamp LH150

- ◆ Convert a forklift truck into a mobile crane to reach and transport long and awkward loads from inaccessible location.
- ◆ Verify load centre of forklift truck.
- ◆ Safety chain wedge to boom has grab hools for anchoring job boom to forklift truck.
- ◆ Zinc plated fork heels pin for safe forklift attachment.
- ◆ Supplied complete with one safety swived hook with the bow shackle and one rigid hook.

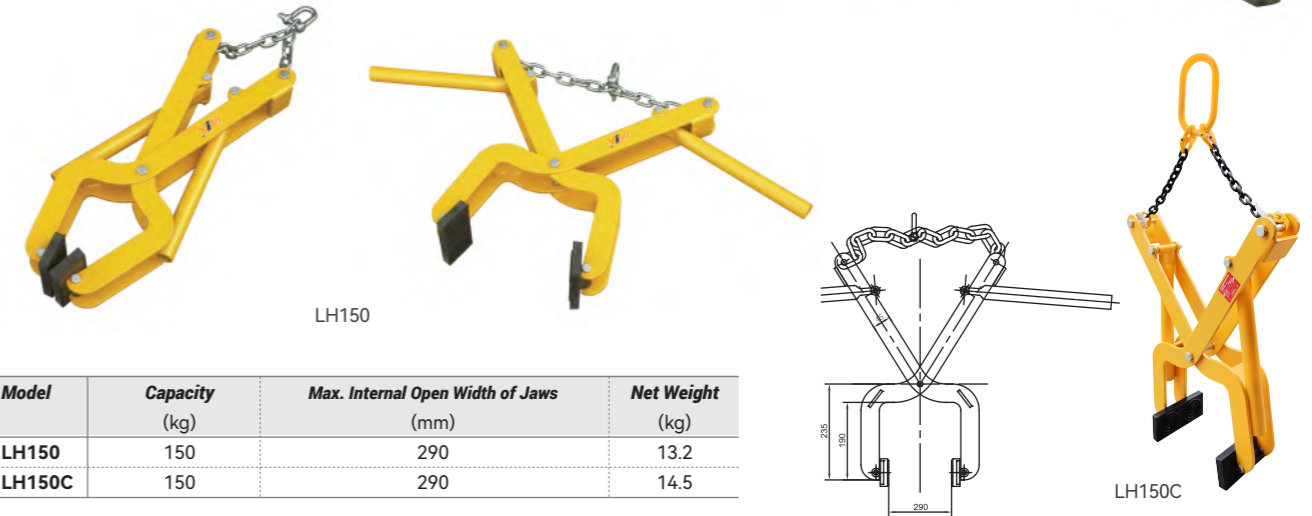

Model	Capacity (kg)	Max. Internal Open Width of Jaws (mm)	Net Weight (kg)
LH150	150	290	13.2
LH150C	150	290	14.5

Drum Lifter Clamp LH200

- ◆ Designed for drum lifting in horizontal direction.
- ◆ 150% overload factory tested.
- ◆ Conforms to EC council directive 98/37/EC machinery, American standard ANSI/ASME B30.

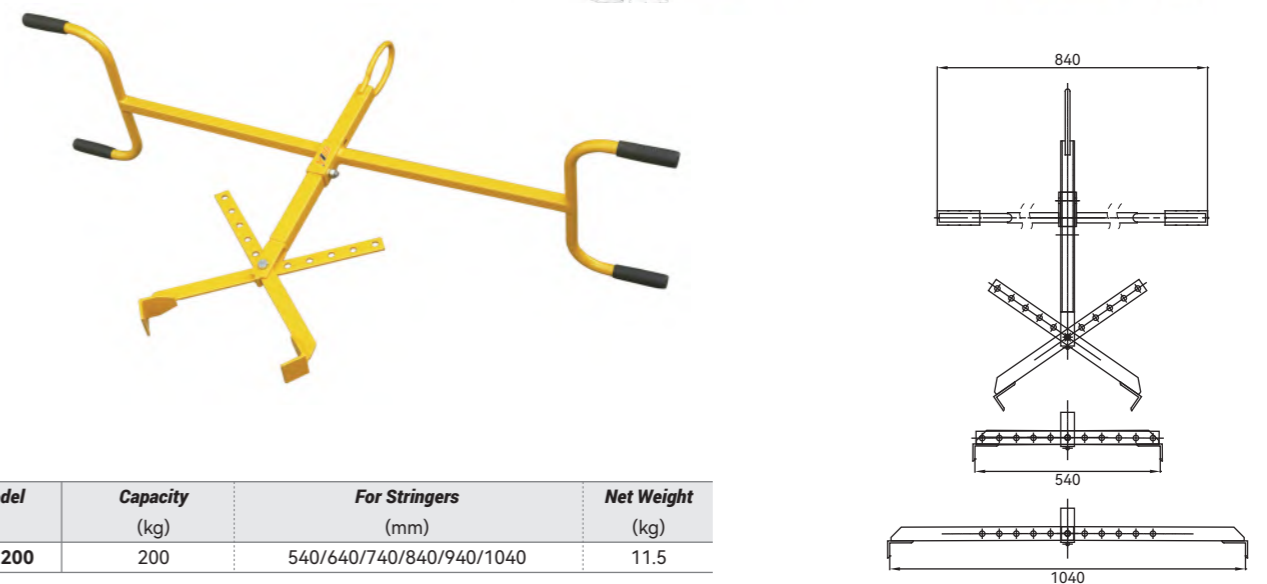
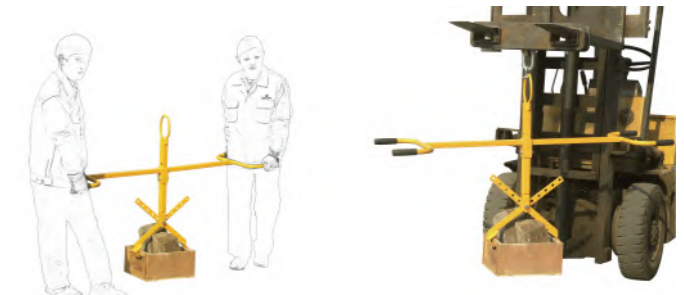

Model	Capacity (kg)	For Stringers (mm)	Net Weight (kg)
LH200	200	540/640/740/840/940/1040	11.5