

Crane Fork **CC-A** series

- ◆ No slings or chains necessary.
- ◆ Crane operator will not need to leave cab of lorry or crane.
- ◆ Forks will remain horizontal when loaded and unloaded.



Model		CC10A	CC15A	CC20A
Work Load Limit WLL	(kg)	1000	1500	2000
Adjustable Fork total Width A	(mm)	320-1500	320-1500	320-1500
Fork Length B	(mm)	1000	1000	1000
Hook Height C+D	(mm)	1650-2095	1650-2095	1800-2270
Fork Cross	(mm)	100×30	100×35	120×40
Net Weight	(kg)	75	115	145

Crane Fork **CC** series

- ◆ No slings or chains necessary.
- ◆ Crane operator will not need to leave cab of lorry or crane.
- ◆ Forks will remain horizontal when loaded and unloaded.



Model		CC10	CC15	CC20
Work Load Limit WLL	(kg)	1000	1500	2000
Adjustable Fork total Width A	(mm)	320-1500	320-1500	320-1500
Fork Length B	(mm)	1000	1000	1000
Hook Height C+D	(mm)	1650-2095	1650-2095	1800-2270
Fork Cross	(mm)	100×30	100×35	120×40
Net Weight	(kg)	146	149	170

Crane Fork **CK / CY** series

- ◆ No slings or chains necessary.
- ◆ Crane operator will not need to leave cab of lorry or crane.
- ◆ Forks will remain horizontal when loaded and unloaded.
- ◆ Adjustable fork width.
- ◆ Adjustable height.

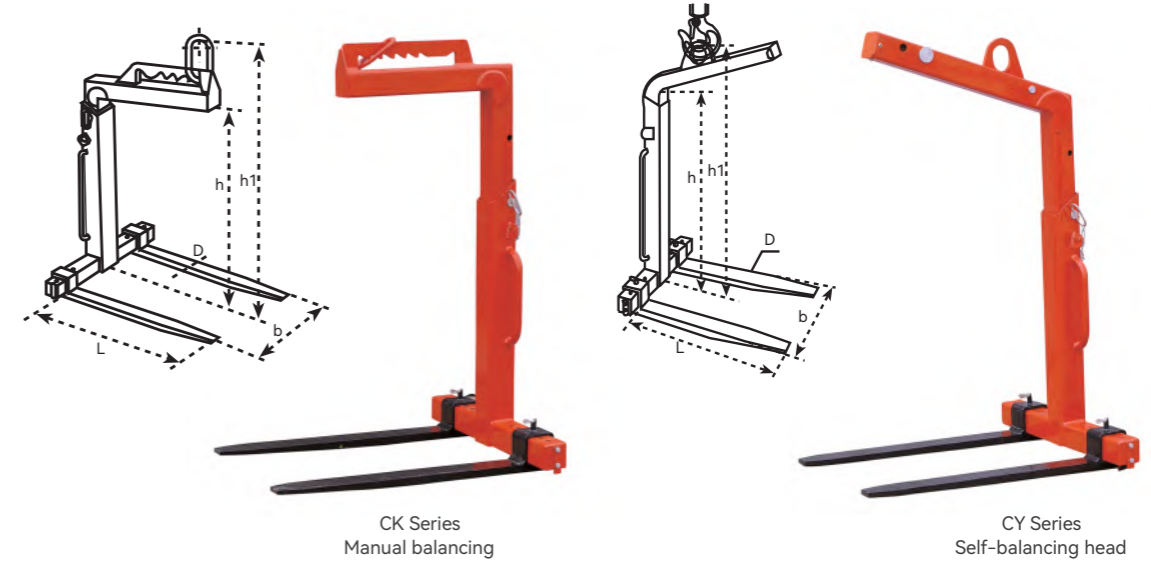

Model	Work Load Limit WLL (tonne)	Adjustable Fork Width b (mm)	Hook Height h1 (mm)	Effective Height h (mm)	Fork Length L (mm)	Fork Cross D (mm)	Overall Size L×W×H (mm)	Net Weight (kg)
CK10	1	350-900	1390-1890	1100-1600	1000	100×30	1120×920×1390	130
CK20	2	400-900	1640-2340	1300-2000	1000	120×40	1140×920×1640	200
CK30	3	450-900	1670-2370	1300-2000	1000	120×50	1140×920×1670	250
CK50	5	530-1000	1700-2400	1300-2000	1000	150×60	1160×1020×1700	370
CY10	1	350-900	1420-1920	1100-1600	1000	100×30	1120×920×1530	140
CY20	2	400-900	1655-2355	1300-2000	1000	120×40	1140×920×1775	220
CY30	3	450-900	1720-2420	1300-2000	1000	120×50	1140×920×1850	280
CY50	5	530-1000	1710-2410	1300-2000	1000	150×60	1160×1020×1850	380

Crane Fork **NY2000**

- ◆ No slings or chains necessary.
- ◆ Crane operator will not need to leave cab of lorry or crane.
- ◆ Forks will remain horizontal when loaded and unloaded.
- ◆ Easily operate by one person with safety.
- ◆ Adjustable fork width with five positions.
- ◆ Three position for adjustable height.



Model		NY2000
Work Load Limit	WLL (T)	2
Adjustable Fork Width	(mm)	370-800
Effective Height	(mm)	1290/1590/1890
Fork Length	(mm)	980
Net Weight	(kg)	180