

Pallet Lifter-Adjustable *PL-A* series

- ◆ Once the bail pin is set the pallet lifter remains balanced whether full or empty to make the job faster and safer.
- ◆ Adjustable bail provides for balanced handling of items with different load centers.
- ◆ Adjustable throat allows for the correct handling of higher stacked loads.
- ◆ Adjustable forks allow for proper placement of the forks spread.
- ◆ The auto return bail automatically levels empty pallet lifter saving time and effort.
- ◆ Heavy duty construction for years of trouble free service.
- ◆ Complies with ASME standards.

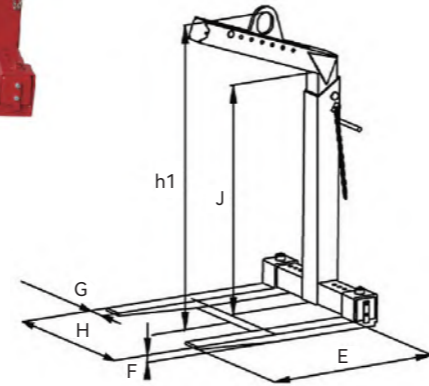

Model		PL-A202
Work Load Limit	WLL (T)	2
Adjustable Fork Width	H (mm)	445-915
Hook Height	h1 (mm)	1448-2190
Effective Height	J (mm)	1035-1632
Fork Length	E (mm)	1092
Fork Cross	G×F (mm)	100×50
Overall Size	L×W×H (mm)	1232×950×1632
Net Weight	(kg)	168

Pallet Lifter *PL-F* series

- ◆ Converts overhead crane to lift truck.
- ◆ Counter balanced to hang level when empty.
- ◆ Maintenance easy.
- ◆ Allows for ease of loading/unloading in not easily accessible areas.
- ◆ Complies with ASME standards.

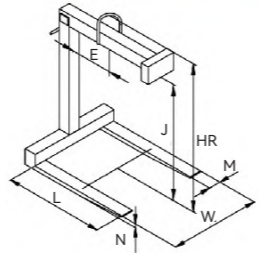
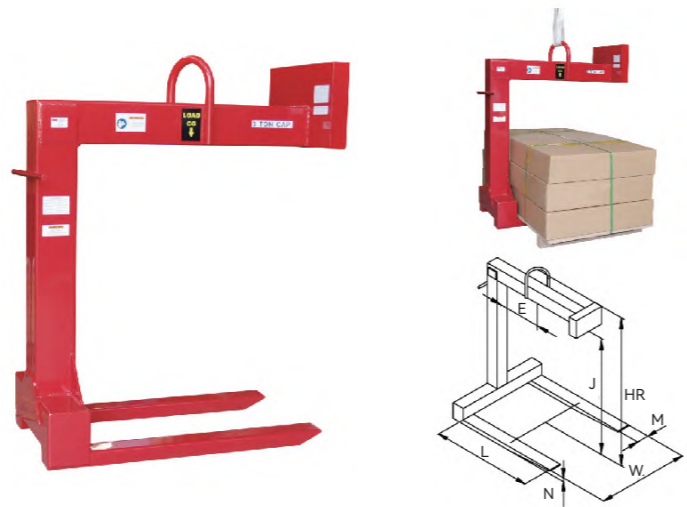

Model		PL-F101	PL-F102	PL-F103	PL-F201	PL-F202	PL-F203	PL-F301	PL-F302	PL-F303
Work Load Limit	WLL (T)	1	1	1	2	2	2	3	3	3
Fork Width	W (mm)	635	635	635	635	635	635	635	685.8	762
Hook Height	HR (mm)	1460	1460	1486	1511	1511	1511	1562	1562	1562
Effective Height	J (mm)	1219	1219	1219	1219	1219	1219	1219	1219	1219
Fork Length	L (mm)	914.4	1066.8	1219	914.4	1066.8	1219	1066.8	1219	1371.6
Fork Cross	M×N (mm)	50×50	50×50	50×50	75×50	100×50	100×50	115×50	115×50	115×50
Overall Size	L×W×H (mm)	1014×635×1535	1167×635×1535	1319×635×1560	1359×635×1585	1359×635×1585	1359×635×1585	1247×635×1664	1399×686×1664	1552×762×1664
Net Weight	(kg)	122	136	138	230	237	250	357	360	390

Pallet Lifter *PL-W* series

- ◆ Dual lift points eliminates need for counterweight.
- ◆ Extremely lightweight for ease of handling.
- ◆ Complies with ASME standards.

PL-W series

- ◆ Wheels allow for movement of unit without crane.

PL-WL series

- ◆ Maintenance free- no moving parts.

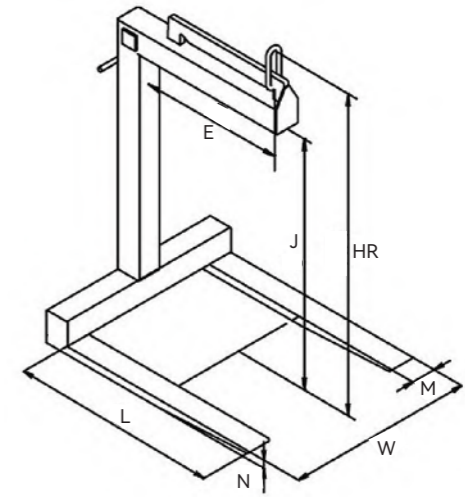

PL-W



PL-WL



Model		PL-W101	PL-W201	PL-WL101	PL-WL201	PL-WL301
Work Load Limit	WLL (T)	1	2	1	2	3
Fork Width	W (mm)	635	635	635	635	685.8
Hook Height	HR (mm)	1524	1575	1473	1575	1651
Effective Height	J (mm)	1219	1219	1219	1219	1219
Fork Length	L (mm)	914	914	914	914	914
Fork Cross	M×N (mm)	50×50	100×50	50×50	100×50	115×65
Overall Size	L×W×H (mm)	1014×700×1539	1054×700×1645	1014×635×1539	1054×635×1645	2008×635×1740