

## Electric Tow Tractor **YL-SM1000 / XFT series**

- ◆ Compact Design, extremely maneuverable, easy operation.
- ◆ Pulling trolley, baggage carts.
- ◆ Standard manual hook electric hook for model YL-SM1000d.
- ◆ Economic type for model XFT.

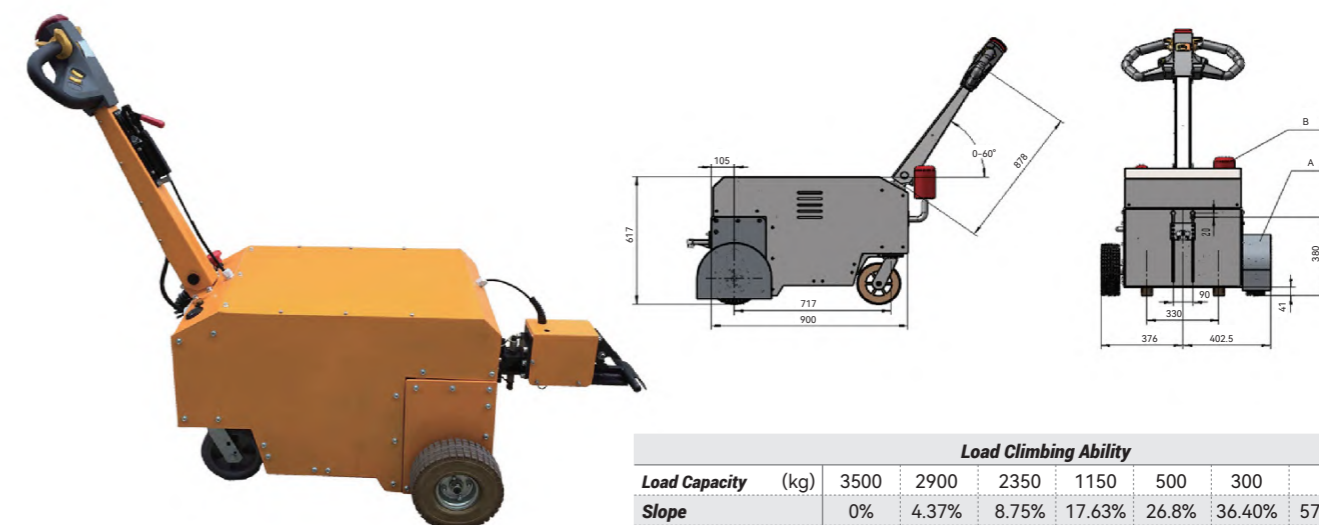

## Electric Tow Tractor **YL-SM3500 series**



Load Climbing Ability							
<b>Load Capacity</b> (kg)	3500	2900	2350	1150	500	300	0
<b>Slope</b>	0%	4.37%	8.75%	17.63%	26.8%	36.40%	57.74%
<b>Angle</b>	0°	2.5°	5°	10°	15°	20°	30°

Model	YL-SM1000N	YL-SM1000D	XFT1000
<b>Capacity</b> (kg)	1000	1000	1000
<b>Rated Drawbar Pull</b> (N)	200	200	-
<b>Wheelbase</b> (mm)	265	265	-
<b>Services Weight</b> (kg)	120	120	59
<b>Axle Loading, Unladen Front/Rear</b> (kg)	75/20	75/20	-
<b>Tires</b>	Solid Rubber	Solid Rubber	Pneumatic
<b>Universal Wheel</b>	Polyurethane	Polyurethane	Polyurethane
<b>Tire Size, Front</b> (mm)	Ø250x86	Ø250x86	Ø250x85
<b>Tire Size, Rear</b> (mm)	Ø75x32	Ø75x32	-
<b>Height of Tiller in Drive Position Min./max.</b> (mm)	850/1200	850/1200	765/1250
<b>Overall Length</b> (mm)	1150	1150	740
<b>Overall Width</b> (mm)	510	510	590
<b>Ground Clearance</b> (mm)	40	40	40
<b>Hook Clamping Height</b> (mm)	240-320	240-320	240-320
<b>Hook Type</b>	Manual	Electric	Manual
<b>Travelling Speed (slow / fast)</b> (km)	1.2-2/3-3.5 (Adjustable)	1.2-2/3-3.5 (Adjustable)	0-5.5
<b>Services Brake</b>	Electromagnetic	Electromagnetic	Electromagnetic
<b>Drive Motor Rating S2 60min</b> (kw)	0.4	0.4	0.4
<b>Battery Voltage, Nominal Capacity</b> (V/Ah)	2x12/30Ah	2x12/30Ah	24/20Ah
<b>Battery Weight</b> (kg)	20	20	14
<b>Type of Drive Control</b>	DC-Speed Control	DC-Speed Control	DC-Speed Control
<b>Sound Level at Driver's Ear Acc. to EN</b> dB(A)	<70	<70	<70
<b>Climbing Ability</b>	<10%	<10%	<10%

Model	YL-SM3500
<b>Capacity</b> (kg)	3500
<b>Wheelbase</b> (mm)	717
<b>Services Weight (with Battery)</b> (kg)	400
<b>Protection Class</b>	Machine IP44
<b>Tires</b>	Solid Rubber
<b>Universal Wheel</b>	Polyurethane (PU)
<b>Tire Size, Front</b> (mm)	Ø250x86
<b>Tire Size, Rear</b> (mm)	200
<b>Overall Length</b> (mm)	900
<b>Overall Width</b> (mm)	752
<b>Ground Clearance</b> (mm)	40
<b>Hook Clamping Height</b> (mm)	630-1200
<b>Hook Type</b>	Manual
<b>Max. Travelling Speed</b> (km/h)	5
<b>Services Brake</b>	Electromagnetic
<b>Drive Motor Rating S2 60 min</b> (V/kw)	36/1.2
<b>Battery Voltage, Nominal Capacity</b> (V/Ah)	3x12/80Ah
<b>Type of Drive Control</b>	DC-Speed Control
<b>Sound Level at Driver's Ear Acc. to EN</b> dB(A)	<70
<b>Climbing Ability</b>	<36.4%
<b>Wheel Shield</b>	Optional
<b>Alarm Lamp</b>	Optional