

Manual Hoist **HCB** series

Best selling in USA

- ◆ Compact design, all steel construction, light handpull.
- ◆ Heat treated low-wear, corrosive resistant chain.
- ◆ Drop-forged hooks designed to bend slowly to warn of overloads.
- ◆ Conforms to CE safety standard.

IMPORTANT:

Before installation, see maintenance and operation manual for additional warnings and precautions. Do not use in explosive environment.

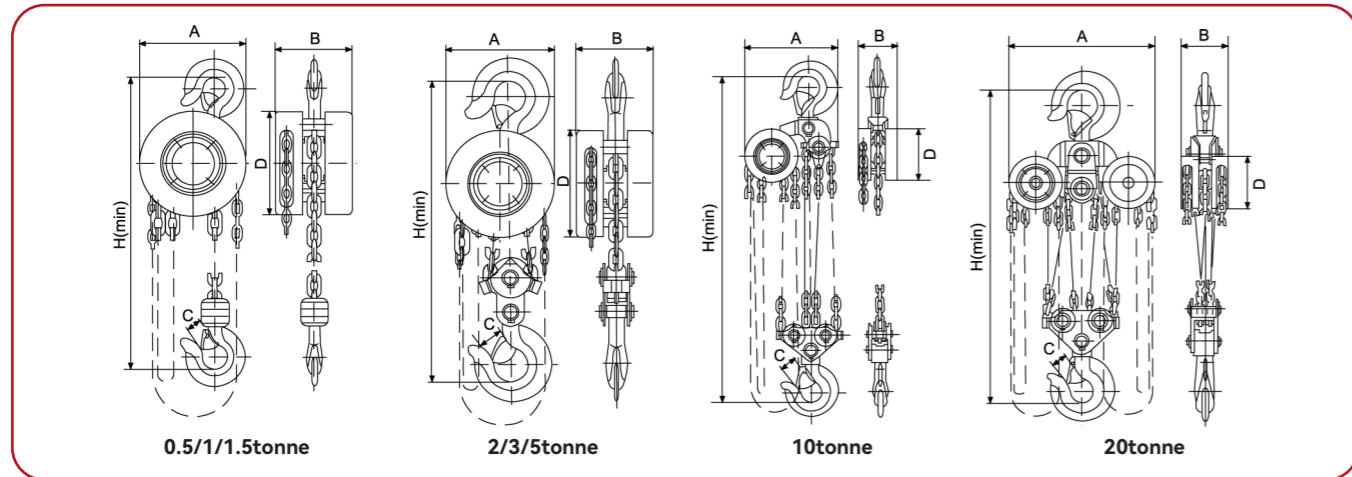
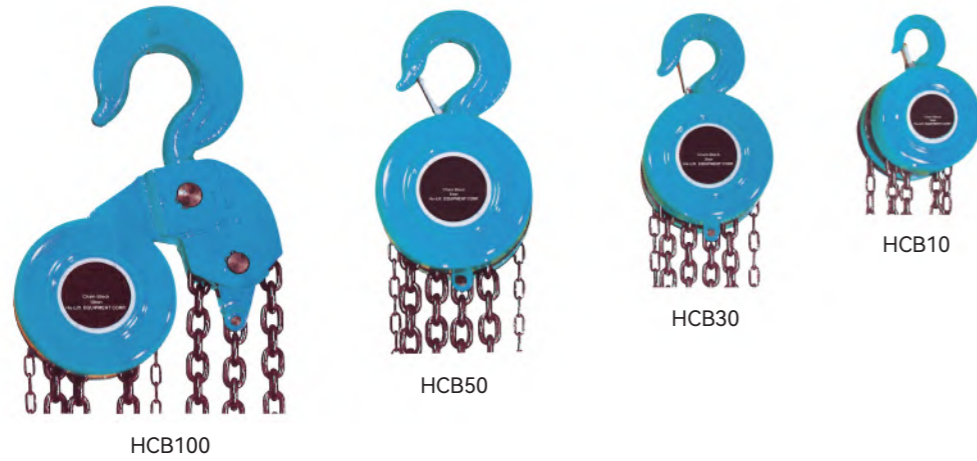

Model	HCBO5	HCBO10	HCBO15	HCBO20	HCBO30	HCBO50	HCBO100	HCBO200
Rated Capacity (kg)	500	1000	1500	2000	3000	5000	10000	20000
Standard Lifting Height (mm)	2500/3000	2500/3000	2500/3000	2500/3000	3000/5000	3000/5000	3000/5000	3000/5000
Test Load (KN)	6.3	12.5	18.8	25	37.5	62.5	125	250
Effort to Rated Capacity (N)	160	310	360	320	360	400	430	430
No. of Load Chain Falls	1	1	1	2	2	2	4	8
Min. Distance between Hooks H (mm)	280	300	360	380	470	600	730	1000
Diameter of Load Chain (mm)	Ø6×18	Ø6×18	Ø8×24	Ø6×18	Ø8×24	Ø10×30	Ø10×30	Ø10×30
Dimensions	A (mm)	142	142	178	142	178	210	358
	B (mm)	130	122	139	122	139	162	189
	C (mm)	24	28	32	34	38	48	82
	D (mm)	142	142	178	142	178	210	358
Net Weight (kg)	9	9.8	9.2	10	14.5	15.3	12	13.5
Gross Weight (kg)	9.4	10.2	9.6	10.4	14.9	15.9	12.6	14
Extra Weight Per Meter of Extra Lift (pcs)	1.65	1.65	2.3	2.5	3.7	5.2	9.6	19.2

Note: In addition to the standard lift height, we accept up to 12m Lifting height.

Manual Hoist **MH** series

One of best selling hoists in Europe

- ◆ Heavy duty and compact design to meet all pertinent world standard.
- ◆ Reliable disc brake and premium grade alloy load chain.
- ◆ Drop-forged and specially heat treated for great strength and durability.
- ◆ Conforms to CE safety standard.

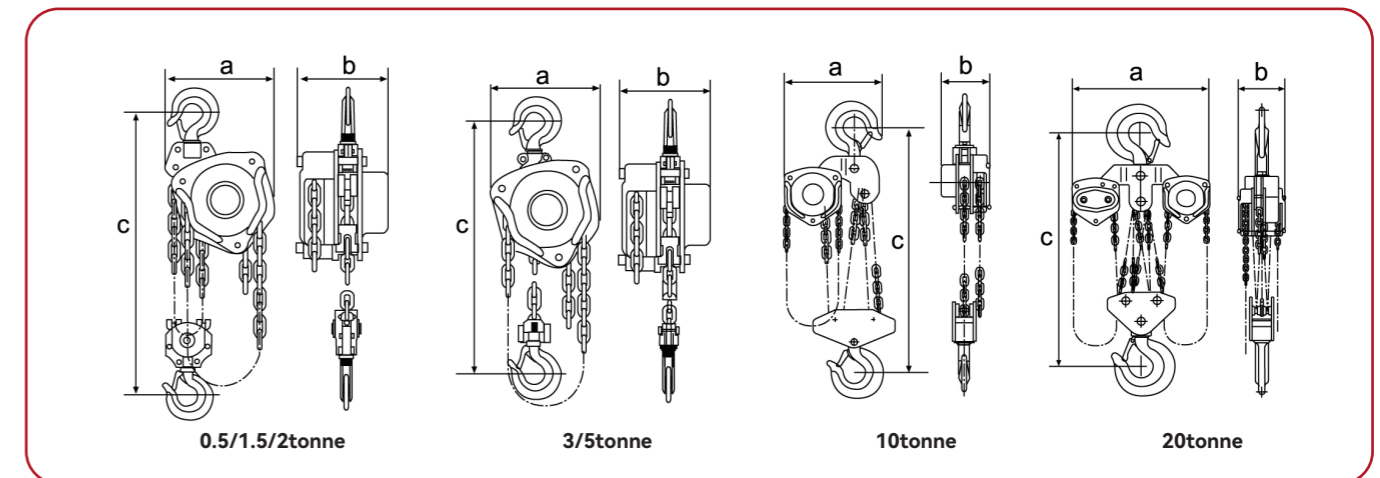
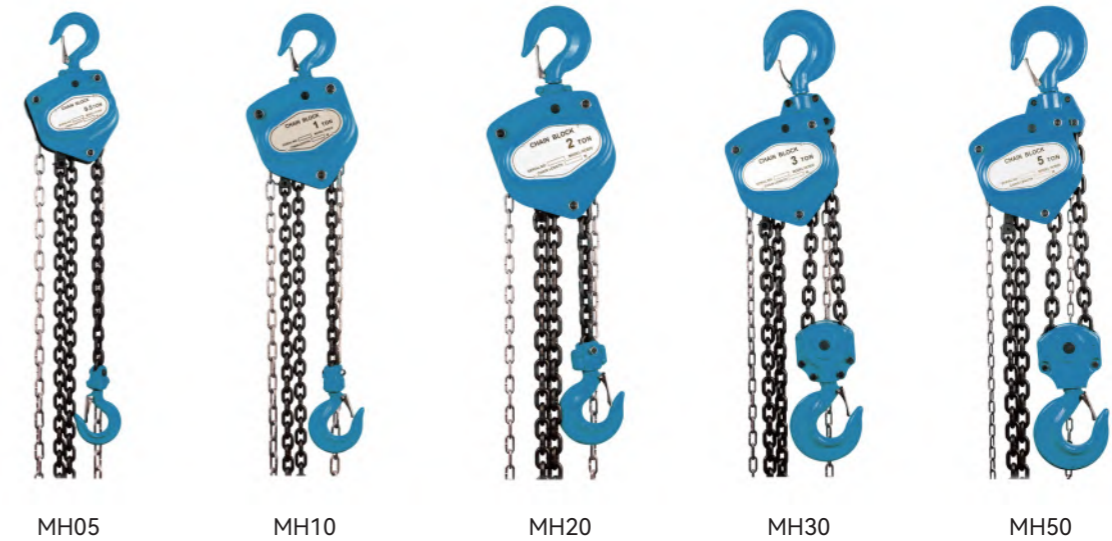

Model	MHO5	MHO10	MHO15	MHO20	MHO30	MHO50	MHO100	MHO200
Rated Capacity (kg)	500	1000	1500	2000	3000	5000	10000	20000
Standard Lifting Height (mm)	2500	2500	2500	3000	3000	3000	3000	3000
Test Load (KN)	6.3	12.5	18.8	25	37.5	75	125	250
Effort to Rated Capacity (N)	231	309	320	360	340	414	414	828
Diameter of Load Chain (mm)	Ø6×18	Ø6×18	Ø8×24	Ø8×24	Ø8×24	Ø10×30	Ø10×30	Ø10×30
No. of Load Chain Falls	1	1	1	1	2	2	4	8
Dimensions	A (mm)	131	140	161	161	161	187	207
	B (mm)	127	158	174	187	199	253	398
	C (mm)	270	317	399	414	465	636	798
Net Weight (kg)	10	12	19	20	27	45	83	193
Extra Weight per Meter of Extra Lift (kg)	1.7	1.7	2.3	2.3	3.7	5.6	9.7	19.4