

Lever Hoist **LW** series

- ◆ Top quality range.
- ◆ Capacity from 0.75 to 6 tonne.
- ◆ Easy for operating.
- ◆ Designed and built for most industrial lifting pulling application.
- ◆ Conforms to CE safety standard.

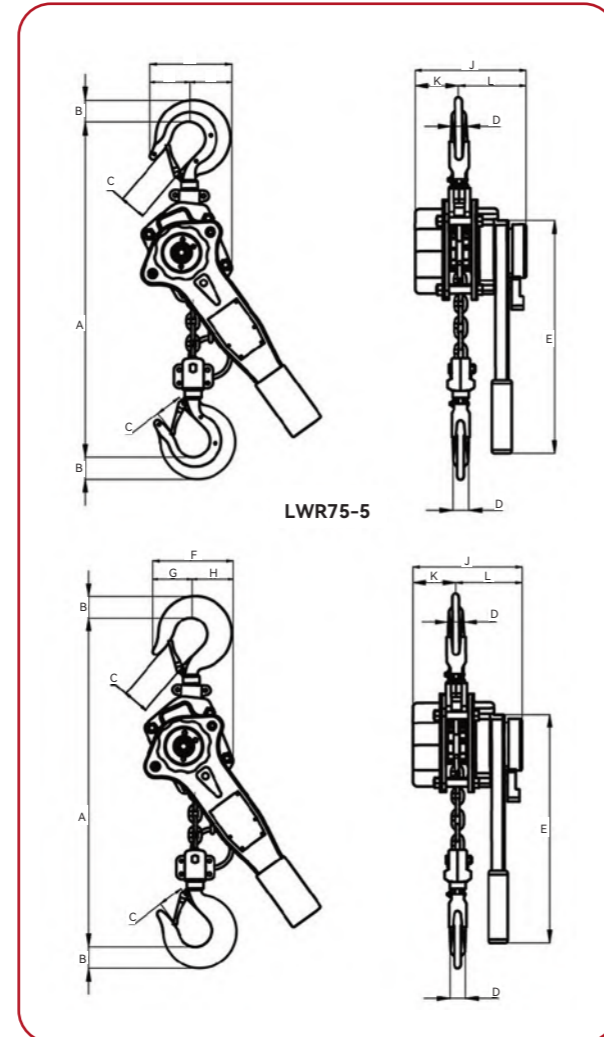

LW75-5



LWR75-5

Model	LW75-5	LW100-5	LW150-5	LW200-5	LW300-5	LW600-5	LW75-10	LW100-10	LW150-10	LW200-10	LW300-10	LW600-10	
Rated Capacity (kg)	750	1000	1500	2000	3000	6000	750	1000	1500	2000	3000	6000	
Standard Lifting Height (mm/foot)	1500/5	1500/5	1500/5	1500/5	1500/5	1500/5	1500/5	1500/5	1500/5	1500/5	1500/5	1500/5	
Effort to Rated Capacity (N)	150	160	230	250	350	370	150	160	230	250	350	370	
Dia. of Load Chain (mm)	Ø6×18	Ø6×18	Ø8×24	Ø8×24	Ø10×30	Ø10×30	Ø6×18	Ø6×18	Ø8×24	Ø8×24	Ø10×30	Ø10×30	
Net Weight (kg)	7.6	7.8	11.5	13.1	21.3	32	7.5	7.7	11.5	12.8	21	31.5	
Dimensions (mm)	A	320	328	380	385	475	320	328	380	385	475	495	
	B	25	30	32	33	40	25	25	25	33	40	50	
	C	25	30	32	38	40	25	25	35	38	38	52	
	D	18	20	25	29	32	40	18	18	20	22	33	
	E	330	330	460	460	460	460	330	330	460	460	460	
	F	135	135	160	160	211	254	135	135	162	162	211	254
	G	40	45	52	58	65	80	37	38	45	47	60	80
	H	58	62	65	83	75	80	58	62	65	83	75	80
J	148	148	175	175	195	195	148	148	175	175	195	195	
K	60	60	70	70	85	85	60	60	70	70	85	85	
L	88	88	102	102	109	109	88	88	102	102	109	109	

Manual Hoist **HSZ** series

- ◆ Heavy duty and compact design to meet all pertinent world standard.
- ◆ Reliable disc brake and premium grade alloy load chain.
- ◆ Drop-forged and specially heat treated for great strength and durability.
- ◆ Conforms to CE safety standard.

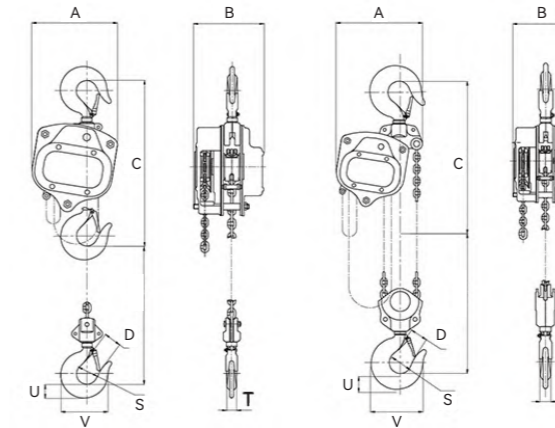

Model	Rated Load (Ton)	Standard Lift (m)	Test Load (Ton)	Efforts Required at Capacity (Ton)	Diameter of Load Chain (mm)	No. of Load Chains	Major Dimensions (approx)(mm)								Net Weight (kg)	Extra Weight Per Meter of Extra List(kg)
							A	B	C	D	S	T	U	V		
HSZ-50A	0.5	2.5	0.75	262	5	1	135	124	288	20	35	17	22	73	7	1.5
HSZ-100A	1	2.5	1.5	304	6	1	160	137	334	25	40	21	28	89	10.5	1.8
HSZ-150A	1.5	2.5	2.25	395	8	1	195	143	415	35	45	25	34	100	15.5	2
HSZ-200A	2	2.5	3	330	6	2	160	137	459	35	51	29	36	115	17	2.7
HSZ-300A	3	3	4.5	402	8	2	195	143	539	36	55	32	47	135	23	3.2
HSZ-500A	5	3	7.5	415	10	2	255	173	660	46	65	42	57	158	39	5.3
HSZ-1000A	10	3	12.5	428	10	4	395	173	738	55	80	40	61	215	69	9.8
HSZ-2000A	20	3	25	428×2	10	8	650	195	1002	80	105	60	92	185	162	19.8
HSZ-50A	30	3	37.5	428×2	10	10	710	398	1050	82	105	65	98	285	237	23.9

Manual Hoist **MIN-LH** series

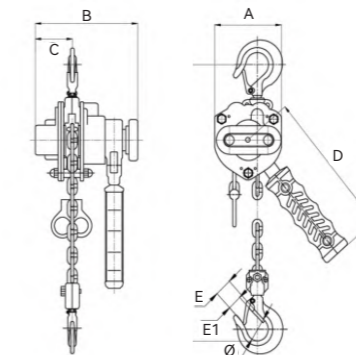

Model	Rated Load (Ton)	Standard Lift (m)	Test Load (Ton)	Min. Distance Between Hooks (mm)	Efforts Required at Capacity (kg)	No. of Load Chains	Load Chain (mm)	Major Dimensions (approx)(mm)								Net Weight (kg)	Extra Weight Per Meter of Extra List(kg)
								A	B	C	D	S	T	Ø	H Min.		
Min-LH-025	0.25	1	0.375	215	13	1	Φ4×12	75	116	41	157	18	15.5	25	215	3.5	0.35
Min-LH-050	0.50	1.5	0.75	255	18.5	1	Φ5×15	90	135	51.5	180	24	21	32	255	3.5	0.55